

# Analyser Specifications

Product Name	OC-SENSOR PLEDIA
Principle	Latex agglutination immunoturbidimetry
Throughput	320 tests/hour
Sample Loading Capacity	10-sample rack × 20 *200-sample rack-tray (optional)
STAT Sample	Up to 10 samples simultaneously
Sample Dilution	15 times and 250 times
Reaction Cuvette	Semi-disposable acrylic cuvette (11 serial cells × 5 cuvettes), Automatic cuvette cleaning with wash solution and purified water
Sampling System	Drawn up by sample nozzle (Liquid surface detection, automatic cleaning with wash solution and purified water)
Reagent Dispense	Drawn up by reagent nozzle (Liquid surface detection, automatic cleaning with purified water)
Mixing System	By spinning mixer (automatic cleaning with wash solution and purified water)
Thermostatic System	Reaction wheel: air bath block heater, Reagent housing: block heater
Light Source	LED (wavelength 660 nm)
Light Detector	Photodiode
Data Input	Color LCD touch panel (10.5 inches)
Memory Capacity	100,000 test results
Data Output	Built-in thermal printer, RS-232C, USB
Barcodes	Rack barcode, sample barcode, reagent barcode, two-dimensional barcode (optional)
Dimensions	W630 mm × D630 mm × H560 mm
Weight	58 kg
Power Required	AC100-240 V 50/60 Hz, 500 VA
Applicable standards and laws	The PMDA Act, CE, TGA, TFDA
Prozone recognition	Prozone of highly concentrated samples is checked through the Primary Rate Check (PRC) method.

# Dimensions

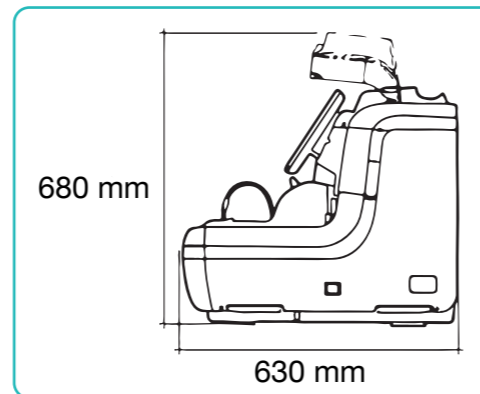
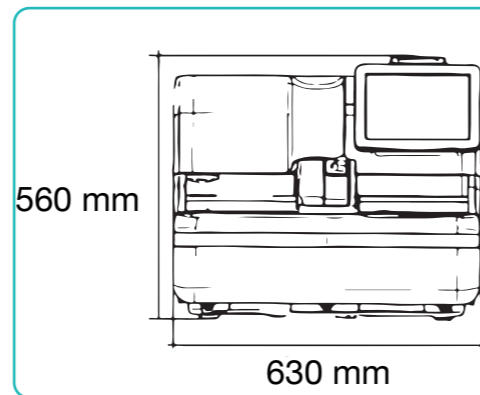

# OC-Sensor PLEDIA

Faecal Immunochemical Test (FIT)  
 Faecal Calprotectin Test (FCa)

- HIGH THROUGHPUT
- COMPACT BODY
- MINIMAL HANDS-ON TIME
- MULTIFUNCTIONAL



# Reagents

## Faecal Immunochemical Test (FIT)

- 28V-PZ01 OC-SENSOR FIT Latex Reagent
- 28V-PZ03 OC-SENSOR FIT Buffer
- 28V-PH53 OC-FIT Control LV1
- 28V-PH54 OC-FIT Control LV2
- 28V-PH59 OC-FIT Control LV3
- 28V-PH52 OC-FIT Calibrator



## Faecal Calprotectin Test (FCa)

- 28V-PH11 OC-FCa Reagent
- 28V-PH13 OC-FCa Control LV1
- 28V-PH14 OC-FCa Control LV2
- 28V-PH15 OC-FCa Control LV3
- 28V-PH12 OC-FCa Calibrator



Please use this product after reading the Operation Manual carefully.

MD V. 1.0 / 2023-11-15

Distributed by:

**Mast Diagnostica GmbH**  
 Feldstraße 20  
 DE-23858 Reinfeld

Tel: +49 (0) 4533 2007 0  
 Fax: +49 (0) 4533 200768  
 E-Mail: mast@mast-diagnostica.de

Website: [www.fit-screening.de](http://www.fit-screening.de) / [www.mast-group.com](http://www.mast-group.com)

Manufacturing company:

**EIKEN CHEMICAL CO., LTD.**  
 4-19-9, Taito-ku, Tokyo 110-8408, Japan



Advena Ltd.  
 Tower Business Centre, 2nd Flr., Tower Street  
 Swatar, BKR 4013 Malta



# Features & Performance



## High Throughput Sampling

Improved processing speed, increased sampling loading capacity

### Throughput

Capable of analysing 320 tests per hour.



### Set reagents

Three reagent slots. PLEDIA is efficient for high throughput population screening.



### On-Board sample capacity

Up to 200 samples can be loaded at a time or by random access. Operation with a tray is optionally available.



### Sample rack detection sensor

Analysis starts automatically when the sample rack is set.



### Squeeze-up System

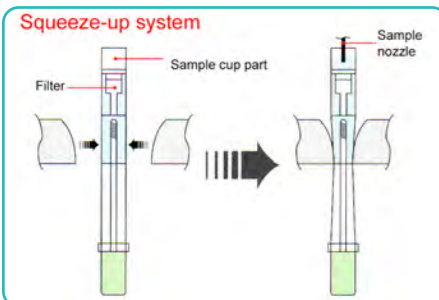

As sampling bottle is squeezed, samples are filtered into sample cup part, and then drawn by the sample nozzle.



## Advanced Usability

Improved screen operability

### User-friendly touch panel

10.5 inch LCD touch panel. The adjustable display angle improves visibility.



### Real-time information

Real-time information is available, incl. information on reagents and sample processing time.

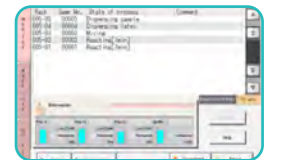

### Quality control function

X-R control screen, CV auto calculation, etc. Massive QC function is available.

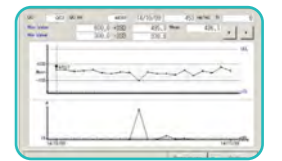

## Fully Automated System

### Full automation

Equipped with the capability for automatic startup, start, and one-touch shut down.

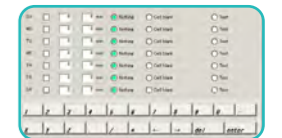

### Automatic identification of measurement modes

Barcodes on racks enable the measurement mode to be identified automatically. Retest racks enable simple re-testing.



With a dilute rack, 15-times and/or 250-times dilution (s) is automatically performed.



### Random Access

### Multiple Items Ordering

Bidirectional communication between PLEDIA and the host allows for multi-item order processing in each sample.



HOST



PLEDIA